

## JUMBO BIN STORAGE UNITS

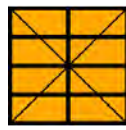

## JUMBO BIN STORAGE UNITS

- Units come complete with polypropylene jumbo bins.
- A cost efficient way to store small, medium and large parts.
- Heavy duty industrial boltless design.
- Boltless design provides for quick, easy assembly and years of dependable service.



Mobile Units

Series 200A Unit

Series 200B Unit

### Mobile Units with Bins

W X D X H	# OF BINS	# OF SHELVES	MODEL NUMBER	WT.	PRICE
48" x 18" x 67"	16	5	QM2-(B/Y/R)260	200	\$623.02
60" x 18" x 67"	20	5	QM3-(B/Y/R)260	232	702.97
48" x 36" x 67"	32	5	QM7-(B/Y/R)260	319	950.57
60" x 36" x 67"	40	5	QM8-(B/Y/R)260	399	1157.27

### Series 200A Units with Bins

W X D X H	# OF BINS	# OF SHELVES	MODEL NUMBER	WT.	PRICE
36" x 18" x 36"	6	3	QK1-(B/Y/R)260	73	\$189.51
48" x 18" x 36"	8	3	QK2-(B/Y/R)260	95	242.18
36" x 18" x 72"	15	6	QL1-(B/Y/R)260	152	421.82
48" x 18" x 72"	20	6	QL2-(B/Y/R)260	197	544.50

### Series 200B Units with Bins

W X D X H	# OF BINS	# OF SHELVES	MODEL NUMBER	WT.	PRICE
36" x 18" x 72"	12	5	QP1-(B/Y/R)260	137	\$375.62
48" x 18" x 72"	16	5	QP2-(B/Y/R)260	176	478.83
60" x 18" x 72"	20	5	QP3-(B/Y/R)260	222	590.32
72" x 18" x 72"	24	5	QP4-(B/Y/R)260	260	694.75
96" x 18" x 72"	32	5	QP5-(B/Y/R)260	337	904.58

## FREE-STANDING BIN STORAGE UNITS

- Provides quick and easy access to small and medium parts.
- Bins can be easily removed from storage units.
- Durable polypropylene bins are virtually crack and chip proof.
- Ideal for use in assembly / production areas.
- Easy to assemble and no special tools required.
- 750 lbs. total unit capacity.
- Units come complete with bins.

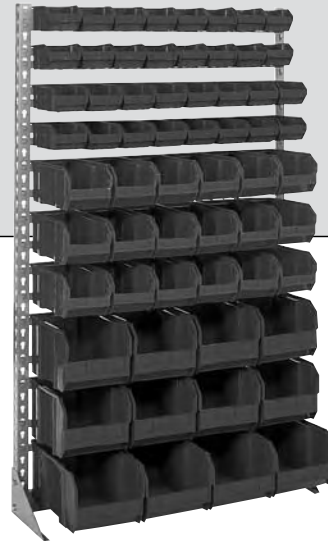

### Bench Rack

BIN D X W X H	# OF ROWS	BINS / ROW	# OF BINS	MODEL NUMBER	WT.	PRICE
5 <sup>3</sup> / <sub>8</sub> " x 4 <sup>1</sup> / <sub>8</sub> " x 3"	5	8	40	QE(B/Y/R)210	25	\$98.87
7 <sup>3</sup> / <sub>8</sub> " x 4 <sup>1</sup> / <sub>8</sub> " x 3"	5	8	40	QE(B/Y/R)220	27	128.83
10 <sup>1</sup> / <sub>8</sub> " x 5 <sup>1</sup> / <sub>2</sub> " x 5"	4	6	24	QE(B/Y/R)230	32	174.45
10 <sup>1</sup> / <sub>8</sub> " x 11" x 5"	4	3	12	QE(B/Y/R)235	28	143.12
10 <sup>3</sup> / <sub>4</sub> " x 8 <sup>1</sup> / <sub>4</sub> " x 7"	3	4	12	QE(B/Y/R)239	26	149.67
5 <sup>3</sup> / <sub>8</sub> " x 4 <sup>1</sup> / <sub>8</sub> " x 3"	1	8	8	QE(B/Y/R)C1 4 total rows	27	\$137.60
7 <sup>3</sup> / <sub>8</sub> " x 4 <sup>1</sup> / <sub>8</sub> " x 3"	1	8	8			
10 <sup>1</sup> / <sub>8</sub> " x 11" x 5"	1	3	3			
10 <sup>3</sup> / <sub>4</sub> " x 8 <sup>1</sup> / <sub>4</sub> " x 7"	2	6	12			

### Single Sided Floor Rack

BIN D X W X H	# OF ROWS	BINS / ROW	# OF BINS	MODEL NUMBER	WT.	PRICE
5 <sup>3</sup> / <sub>8</sub> " x 4 <sup>1</sup> / <sub>8</sub> " x 3"	12	8	96	QF(B/Y/R)210	57	\$211.60
7 <sup>3</sup> / <sub>8</sub> " x 4 <sup>1</sup> / <sub>8</sub> " x 3"	12	8	96	QF(B/Y/R)220	60	283.51
10 <sup>7</sup> / <sub>8</sub> " x 5 <sup>1</sup> / <sub>2</sub> " x 5"	9	6	54	QF(B/Y/R)230	69	374.09
10 <sup>7</sup> / <sub>8</sub> " x 11" x 5"	9	3	27	QF(B/Y/R)235	60	303.60
10 <sup>3</sup> / <sub>4</sub> " x 8 <sup>1</sup> / <sub>4</sub> " x 7"	7	4	28	QF(B/Y/R)239	57	326.78
14 <sup>3</sup> / <sub>4</sub> " x 8 <sup>1</sup> / <sub>2</sub> " x 7"	7	4	28	QF(B/Y/R)240	78	391.49
14 <sup>3</sup> / <sub>4</sub> " x 16 <sup>1</sup> / <sub>2</sub> " x 7"	7	2	14	QF(B/Y/R)250	66	313.00
5 <sup>3</sup> / <sub>8</sub> " x 4 <sup>1</sup> / <sub>8</sub> " x 3"	2	8	16	QF(B/Y/R)C1 10 total rows	69	\$360.48
7 <sup>3</sup> / <sub>8</sub> " x 4 <sup>1</sup> / <sub>8</sub> " x 3"	2	8	16			
10 <sup>7</sup> / <sub>8</sub> " x 5 <sup>1</sup> / <sub>2</sub> " x 5"	3	6	18			
10 <sup>3</sup> / <sub>4</sub> " x 8 <sup>1</sup> / <sub>4</sub> " x 7"	2	4	8			
14 <sup>3</sup> / <sub>4</sub> " x 8 <sup>1</sup> / <sub>2</sub> " x 7"	1	4	4			

**STACKABLE BINS**

- Stackable bins are made of heavy duty polypropylene with permanent molded-in color.
- Bins are virtually unbreakable and are water, rust and corrosion-proof.
- Finger grips are provided for ease of handling.
- Bins have reinforced ribs to prevent them from spreading under load.
- Bins have large slotted label area.
- Choose from 9 different sizes and 3 different colors.
- Bins are locally stocked and offer quick shipment.

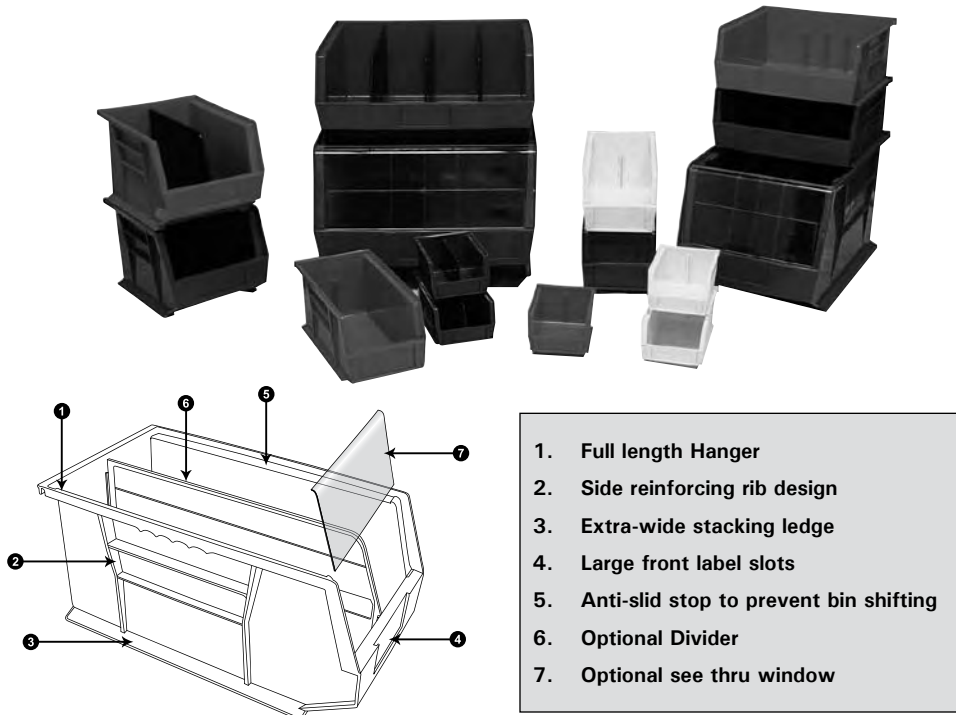

1. Full length Hanger
2. Side reinforcing rib design
3. Extra-wide stacking ledge
4. Large front label slots
5. Anti-slid stop to prevent bin shifting
6. Optional Divider
7. Optional see thru window

**Stackable Bins**

OUTSIDE D X W X H	*CARTON QTY.	BLUE BINS	YELLOW BINS	RED BINS	WEIGHT	*PRICE
5 <sup>3</sup> / <sub>8</sub> " x 4 <sup>1</sup> / <sub>8</sub> " x 3"	24	225-QTB210	225-QTY210	225-QTR210	.20	\$1.26 ea.
7 <sup>3</sup> / <sub>8</sub> " x 4 <sup>1</sup> / <sub>8</sub> " x 3"	24	225-QTB220	225-QTY220	225-QTR220	.25	2.01 ea.
10 <sup>7</sup> / <sub>8</sub> " x 5 <sup>1</sup> / <sub>2</sub> " x 5"	12	225-QTB230	225-QTY230	225-QTR230	.70	5.25 ea.
10 <sup>7</sup> / <sub>8</sub> " x 11" x 5"	6	225-QTB235	225-QTY235	225-QTR235	1.10	7.90 ea.
10 <sup>3</sup> / <sub>4</sub> " x 8 <sup>1</sup> / <sub>4</sub> " x 7"	6	225-QTB239	225-QTY239	225-QTR239	1.15	8.44 ea.
14 <sup>3</sup> / <sub>4</sub> " x 8 <sup>1</sup> / <sub>2</sub> " x 7"	12	225-QTB240	225-QTY240	225-QTR240	1.90	10.75 ea.
14 <sup>3</sup> / <sub>4</sub> " x 16 <sup>1</sup> / <sub>2</sub> " x 7"	6	225-QTB250	225-QTY250	225-QTR250	2.90	15.90 ea.
18" x 11" x 10"	4	225-QTB260	225-QTY260	225-QTR260	4.25	19.90 ea.
18" x 16 <sup>1</sup> / <sub>2</sub> " x 11"	3	225-QTB270	225-QTY270	225-QTR270	5.35	26.62 ea.

**Clear Plastic Windows**

**Bin Dividers**

FITS BIN SIZE	MODEL NUMBER	*CARTON QTY.	PRICE	MODEL NUMBER	*CARTON QTY.	*PRICE
5 <sup>3</sup> / <sub>8</sub> " x 4 <sup>1</sup> / <sub>8</sub> " x 3"	N/A	N/A	N/A	225-QTAD210	6	\$0.85 ea.
7 <sup>3</sup> / <sub>8</sub> " x 4 <sup>1</sup> / <sub>8</sub> " x 3"	N/A	N/A	N/A	225-QTAD220	6	0.95 ea.
10 <sup>7</sup> / <sub>8</sub> " x 5 <sup>1</sup> / <sub>2</sub> " x 5"	225-QTAW230	12	\$1.11 ea.	225-QTAD230	6	1.46 ea.
10 <sup>7</sup> / <sub>8</sub> " x 11" x 5"	225-QTAW235	6	1.58 ea.	225-QTAD235	6	1.46 ea.
10 <sup>3</sup> / <sub>4</sub> " x 8 <sup>1</sup> / <sub>4</sub> " x 7"	225-QTAW239	6	1.46 ea.	225-QTAD239	6	1.80 ea.
14 <sup>3</sup> / <sub>4</sub> " x 8 <sup>1</sup> / <sub>2</sub> " x 7"	225-QTAW240	12	1.46 ea.	225-QTAD240	6	2.48 ea.
14 <sup>3</sup> / <sub>4</sub> " x 16 <sup>1</sup> / <sub>2</sub> " x 7"	225-QTAW250	6	3.20 ea.	225-QTAD250	6	2.48 ea.
18" x 11" x 10"	225-QTAW260	4	2.70 ea.	225-QTAD260	6	4.44 ea.
18" x 16 <sup>1</sup> / <sub>2</sub> " x 11"	225-QTAW270	3	3.83 ea.	225-QTAD270	6	4.76 ea.

*\* Sold in Carton Quantities Only*